

**TERROVA 55**  
**55 LBS THRUST**  
**12 VOLT 50 AMPS**  
**48" OR 54" SHAFT**

for use with "L" serial numbers  
 2-year warranty

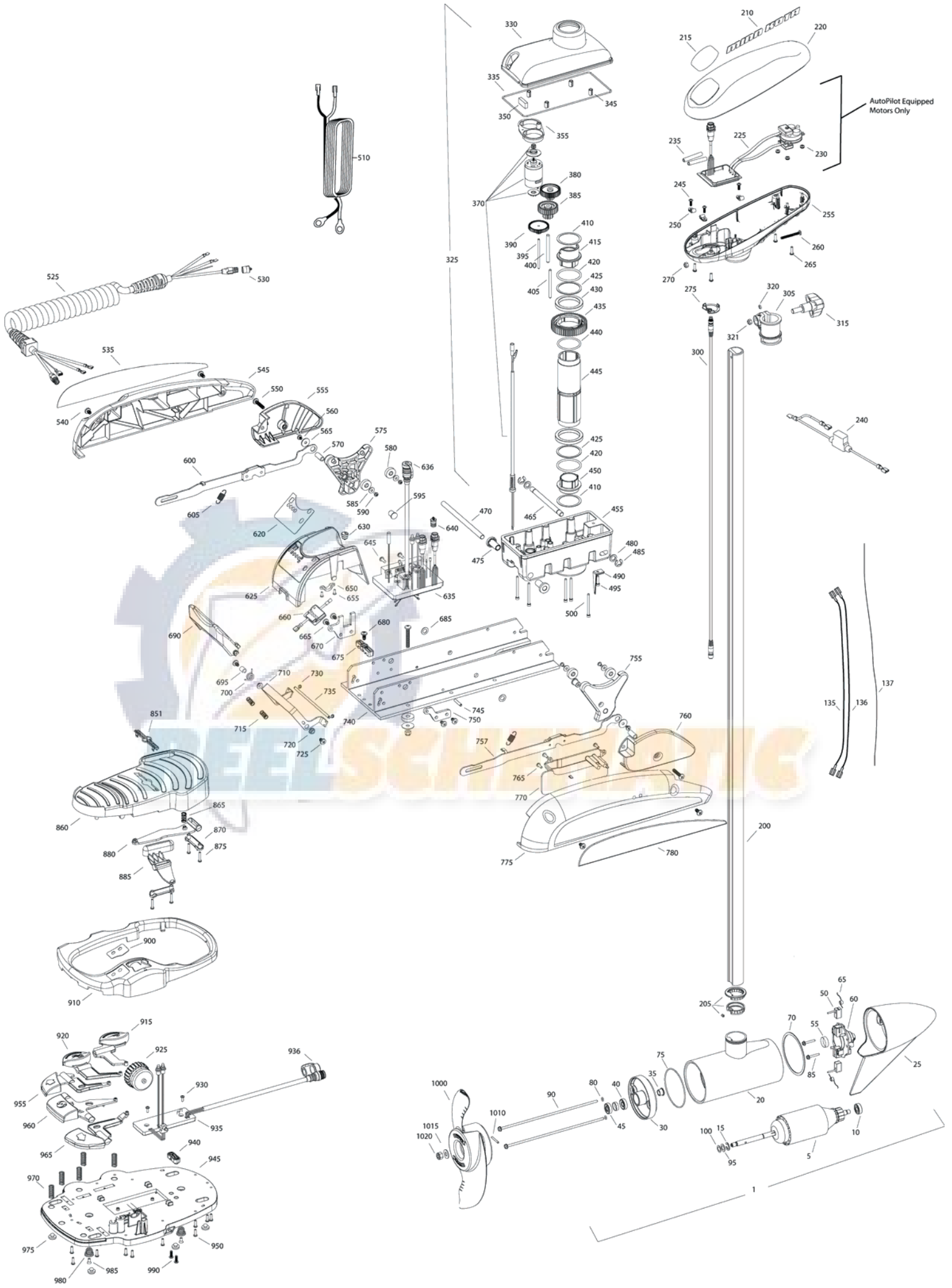

In the U.S.A., replacement parts may be ordered directly from MINN KOTA Parts Dept., 121 Power Drive, P.O. Box 8129 Mankato, Minnesota 56002-8129. In Canada, parts may be ordered from any of the Canadian Authorized Service Centers shown on the enclosed list. Be sure to provide the MODEL and SERIAL numbers of your motor when ordering parts. Please use the correct part numbers from the parts list. Payment for any parts ordered from the MINN KOTA parts department, may be by cash, personal check, Discover Card, MasterCard or VISA. To order, call 1-800-227-6433 or FAX 1-800-527-4464.

Fuera de los Estados Unidos, consultar la lista anexa para ubicar el Centro de servicio autorizado MINN KOTA. No dejar de incluir el número del MODELO y el número de SERIE del motor para el cual se solicitan las piezas. Usar siempre los números de pieza correctos indicados en la lista de piezas.

Item	P/N	Description	Qty	Item	P/N	Description	Qty	Item	P/N	Description	Qty	Item	P/N	Description	Qty
1	2779021	12V Motor 54" FW	1	325	2997050	Steering housing	1	625	2320210	Cover, speed control	1	960	2323705	Button, momentary	1
	2779020	12V Motor 48" FW	1	330	2326501	Steering housing top	1	630	2322901	Strain relief	1	965	2323701	Button, steer, right	1
	2779023	12V Motor US2 54"	1	335	2324604	O-ring, case seal	1	635	2324011	Control board, 12v	1	970	2322704	Spring, foot pedal	5
	2779022	12V Motor US2 48"	1	345	2305605	Roll pin 5/16	4	■	2884050	Switch-reed repair kit	1	975	2994859	Bumper, bag assy	1
5	2-100-146	Armature assembly	1	350	2308601	Breather, filter	1	636	2320208	Dust plug	1	980	2322706	Spring, barrel	2
10	140-010	Bearing	1	355	2328610	Cradle, motor	1	640	2320203	Cap, dust, control board	1	985	2323420	Screw, 8-18 x .375	2
15	788-015	Retaining ring	1	370	2777055	Motor, steering, assy	1	645	2323406	Screw, 10-24 x	2	990	2372100	Screw, 8-18 x .625	2
20		Included in #200 assembly		380	2302255	Gear, cluster 3rd stage	1	650	2321315	Holder, connector	1				
25	421-050	Brush end housing assembly STD	1	385	2302250	Gear, cluster 2nd stage	1	655	2332103	Screw, 6-20 x .375	2	■	1378131	Propeller kit WW2	
	9421-146	Plain end housing US2 54"	1	390	2302245	Gear, cluster 1st stage	1	660	2074070	Battery meter, 12v	1	■	2994875	Propeller bag assy	
	9421-145	Plain end housing US2 48"	1	395	2302610	Shaft, gear 1st stage	1	665	2323402	Screw, 1/4-20 x .375	4	1000	2091160	Propeller WW2	1
30	2-400-101	Plain end housing assembly	1	400	2302620	Shaft, gear 3rd stage	1	670	2321940	Bracket, strain relief	1	1010	2092600	Drive pin, small	1
35	144-049	Flange bearing	1	405	2302615	Shaft, gear 2nd stage	1	675	2321310	Strain relief, wire	1	1015	2151726	Washer, prop, small	1
40	880-003	Seal	1	410	2321704	Washer, thrust	2	680	2323405	Screw, 1/4-20 x .5	1	1020	2053101	Nut, nylock, prop, small	1
45	880-006	Seal with shield	1	415	2321515	Liner, output tube	1	685	2013100	Speed nut, .375	2				
50	188-036	Brush	2	420	2324608	O-ring, 224	2	690	2320215	Handle, release cover	1	■	2994864	Mounting hardware bag assy	
55	725-050	Paper tube	1	425	2321720	Shim, O-ring	2	695	2301700	Bushing,	1	■	2888460	Seal & Oring Kit	
60	738-036	Brush plate assembly	1	430	2327308	Bearing, ball sealed	2	700	2322701	Spring, release handle	1				
65	975-040	Brush spring	2	435	2322200	Gear, output	1	710	2320400	Handle, release FW	1				
70	337-036	Gasket	1	440	2324601	O-ring, output gear	1	715	2322712	Spring, release handle	2				
75	701-081	O-ring, motor	1	445	2322030	Tube, output machined	1	720	2322604	Bushing, handle	2				
80	701-008	O-ring, thru-bolt	2	450	2321510	Collar, drive, bottom	1	725	2332104	Screw, 1/4-20 x .625	2				
85	830-007	Screw, 8-32	2	455	2326506	Steering housing, Bottom	1	730	2323000	E-clip, 3/16, SS	2				
90	830-008	Thru-bolt	2	465	2322600	Pin, latch, zp	1	735	2322606	Pin, follower, handle	1				
95	990-067	Washer, steel	2	470	2322602	Pin, pivot, zp	1	740	2321901	Base extrusion, machined	1				
100	990-070	Washer, nylatron	2	475	2327310	Bushing, pivot pin	2	745	2322912	Spring pin,	2				
135	640-031	Leadwire, black	1	480	2321702	Washer, flat .375	2	750	2321950	Bracket, sideplate	1				
136	640-135	Leadwire, red	1	485	2263011	E-ring .375	2	755	2323910	Ramp, 3 5/8" right	1				
137	640-316	Groundwire, brown, US2 only	1	490	2322702	Spring, latch pin	2	757	2994204	Arm, release, Right	1				
200	2779105	Tube, composite 54" FW	1	495	2323410	Screw, 8-32 x .75	1	760	2321920	Skid, right	1				
205		Included in #200 assembly		500	2323408	Screw, 8-32 x 2	7	765	2301310	Screw, 8-18 x .5	3				
210	2325665	Decal, cover	2	510	2090651	Leawire, 10 ga	1	770	2320220	Cover, access, FW	1				
215	2325670	Decal, ctrl box 55	1	525	2991273	Coil cord, 45"	1	775	2321910	Sideplate, right	1				
	2325671	Decal, ctrl box 55 US2	1		2991271	Coil cord, 54"	1	780	2325640	Decal, sideplate, right	1				
	2325672	Decal, ctrl box 55 Autopilot	1		2991274	Coil cord, US2, 45"	1	850	2994720	Foot pedal	1				
	2325673	Decal, ctrl box 55 Autopilot & US2	1		2991272	Coil cord, US2, 54"	1	851	2326710	Plug, foot pedal	1				
220	2320200	Cover, ctrl box	1	530	2320202	Cap, dust, coil cord, non-AP only	1	860	2324400	Pedal, heel-toe	1				
225	2324030	Ctrl board, compass, Autpilot only	1	535	2325641	Decal, sideplate, left	1	865	2322714	Spring, momentary	1				
230	2302960	Grommet, compass, Autopilot only	3	540	2323404	Screw, 1/4-20	4	870	2321300	Clamp	2				
235	2065400	Wire insulator	2	545	2321915	Sideplate, left	1	875	2223430	Screw, 8 x .75	4				
240	2218200	Fuse Holder, US2 only	1	550	2323403	Screw, 1/4-20 x .375 SS CRPH	2	880	2328600	Flex finger	1				
245	2372100	Screw, 8-18 x .625	3	555	2321925	Skid, left	1	885	2323710	Button, momentary, left	1				
250	2052510	Cable clamp	3	560	2323422	Screw, 10-24 x .375	2	900	2325660	Decal, foot pedal	1				
255	2322500	Ctrl box	1	565	2321700	Washer, #10 SS	2	910	2320205	Cover, heel-toe	1				
260	2332102	Screw, 10-24	1	570	2323500	Bolt, shoulder	2	915	2323725	Button, AP	1				
265	2372100	Screw, 8-18 x .625	4	575	2323915	Ramp, 3 5/8" left	1	920	2323715	Button, Mom/Con	1				
270	2333101	Nut, 10-24	1	580	2325115	Pad, rubber rest	4	925	2320100	Knob, speed, foot pedal	1				
275	2224700	Plug, ctrl box, US2 motors only	1	585	2321706	Washer, #8	4	930	2332103	Screw, 6-20 x .375	2				
	2224702	Plug, ctrl box	1	590	2323412	Screw, 8-18 x .25	4	935	2324020	Control board, foot pedal	1				
300	2211415	Universal sonar 2 extension cable	1	595	2324705	Insert, ramp	2	936	2320207	Dust cap	1				
305	2771500	Depth collar Assembly	1	600	2994202	Arm, release, left	1	940	2322900	Strain relief, foot pedal	1				
315	2260906	Knob (included in #305)	1	605	2322710	Spring, extension	2	945	2324500	Base plate, foot pedal	1				
320	2321706	Washer (included in #305)	1	■	2770250	Cover, speed control with decal	1	950	2301310	Screw, #8 x .5	10				
321	2323102	Nut (included in #305)	1	620	2325650	Decal, speed control	1	955	2323700	Button, steer, left	1				

\* This item is part of an assembly. This item cannot be sold separately due to machining and/or assembly that is required.

P/N 2324930

REV. X 31552

8-09

# Terrova 55 is 12-v only!

**THIS IS A UNIVERSAL MULTI-VOLTAGE DIAGRAM. DOUBLE CHECK YOUR MOTORS VOLTAGE FOR PROPER CONNECTIONS**  
**CECI EST UN SCHEMA À TENSION MULTIPLE UNIVERSEL. REVÉRIFIEZ LA TENSION DE VOTRE MOTEUR POUR BIEN LE BRANCHER.**

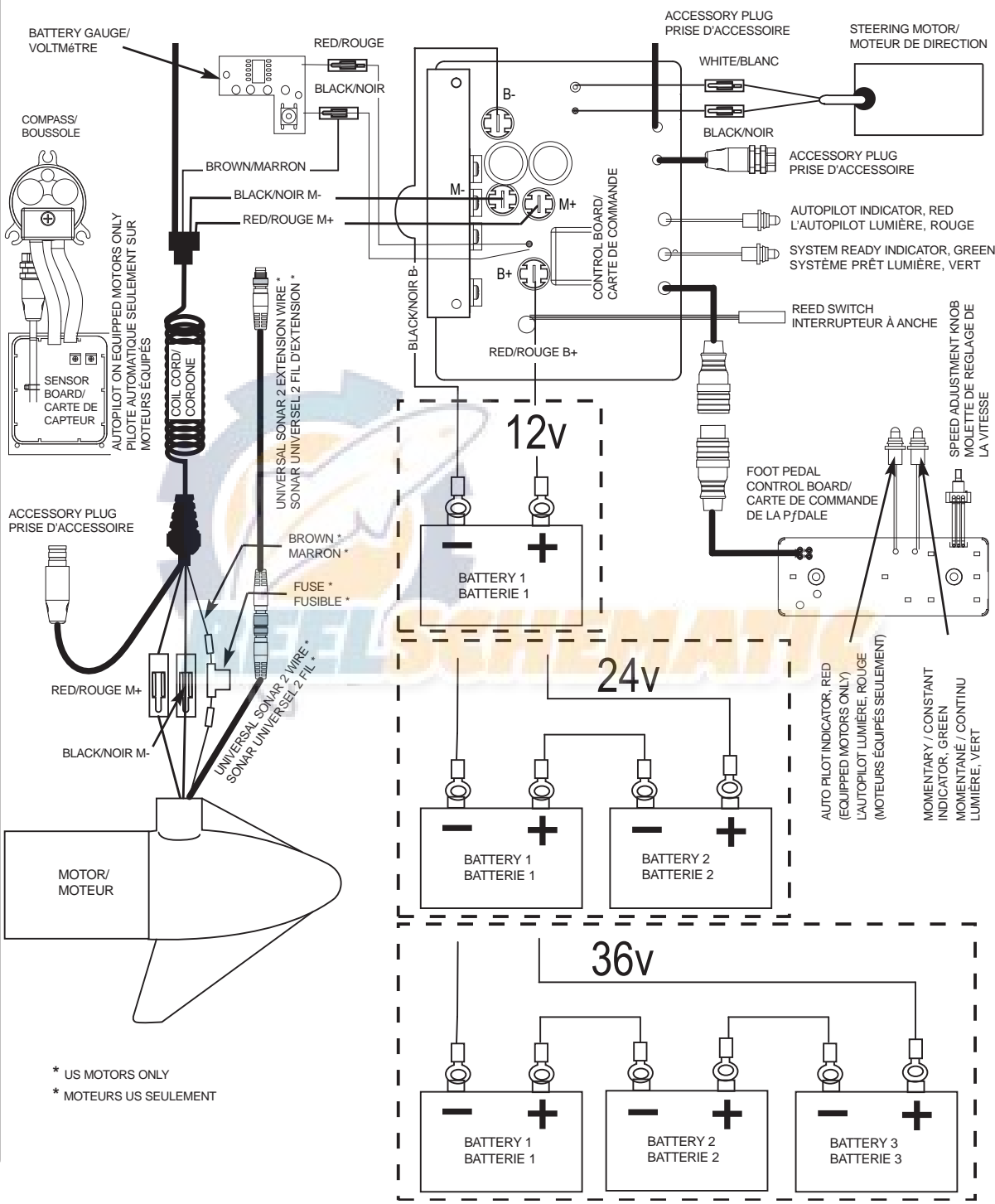

\* US MOTORS ONLY  
 \* MOTEURS US SEULEMENT